



Fisherbrand GT2 Centrifuge

Fisherbrand GT2R Centrifuge

50156459-b • 11 / 2020

15808722

15818722

IMPORTANT Read this instruction manual. Failure to follow the instructions in this manual can result in damage to the unit, injury to operating personnel and poor equipment performance.

CAUTION All internal adjustments and maintenance must be performed by qualified service personnel.

Material in this manual is for informational purposes only. The contents and the product it describes are subject to change without notice. Thermo Fisher Scientific makes no representations or warranties with respect to this manual. In no event shall be held liable for any damages, direct or incidental, arising from or related to the use of this manual.

BIOShield™, Fiberlite™, HIGHConic™, Microliter™, MicroClick™ and Auto-Lock™.

All trademarks are the property of Thermo Fisher Scientific Inc. and its subsidiaries unless otherwise specified.

© 2020 Thermo Fisher Scientific Inc. All rights reserved.

Contents

Preface	1
Scope of Supply.....	1
Intended Use.....	1
Accident Prevention	1
Precautions.....	1
Introduction and Description	3
Characteristics	3
Technical Data	3
Directives, Standards and Guidelines	4
Functions and Features	4
Mains Supply	5
Refrigerant	5
Rotor Selection	6
Before Use.....	7
Before Setting up	7
Transporting the Centrifuge	7
Location	7
Aligning the Centrifuge	7
Mains Connection	8
Storage.....	8
Control Panel	9
Control Panel	9
Keys.....	9
Operation.....	10
Switch ON Centrifuge.....	10
Lid Opening	10

Close Lid.....	10
Rotor Installation	10
Entering Parameters.....	11
Saving programs.....	12
Centrifugation.....	12
Temperature Adaptation during Standstill.....	13
Short-term Centrifugation	13
Removing the Rotor	13
Aerosol-Tight Rotors	14
Aligning the Centrifuge	14
System Menu.....	15
Description.....	16
Maintenance and Care.....	17
Cleaning Intervals	17
Cleaning.....	17
Disinfection	18
Decontamination	18
Autoclaving	19
Maintenance and repair Services.....	19
Troubleshooting.....	20
Mechanical Emergency Door Release	20
Troubleshooting by User	21
When to Contact Customer Service	24
Chemical Compatibility Chart	25

Preface

Before starting to use the centrifuge, read through this instruction manual carefully and follow the instructions.

The information contained in this instruction manual is the property of Thermo Fisher Scientific; it is forbidden to copy or pass on this information without explicit approval.

Failure to follow the instructions and safety information in this instruction manual may void the seller's warranty.

Scope of Supply

Item Description	Quantity	Check
Centrifuge GT 2 / 2R	1	<input type="checkbox"/>
Power supply cable	1	<input type="checkbox"/>
Instruction manual	1	<input type="checkbox"/>
CD	1	<input type="checkbox"/>
Anti-corrosion oil	1	<input type="checkbox"/>

If any parts are missing, contact your nearest Fisher Scientific sales representative.

Intended Use

This centrifuge is designed to separate sample mixtures of different densities like chemicals, environmental samples and other non-human body samples.

Accident Prevention

Prerequisite for the safe operation of the Fisherbrand GT 2 / 2R Centrifuge is a work environment in compliance with standards, directives and trade association safety regulations and proper instruction of the user.

The safety regulations contain the following basic recommendations:

- Maintain a radius of at least 30 cm around the centrifuge.

- Implementation of special measures which ensure that no one can approach the centrifuge for longer than absolutely necessary while it is running.
- The mains plug must be freely accessible at all times. Pull out the power supply plug or disconnect the power supply in an emergency.

Precautions

In order to ensure safe operation of the Fisherbrand GT 2 / 2R Centrifuge, the following general safety regulations must be followed:

- Do not manipulate the safety devices.
- The centrifuge should be operated by trained specialists only.
- The centrifuge is to be used for its intended use only.
- Plug the centrifuge only into sockets which have been properly grounded.
- Do not move the centrifuge while it is running.
- Do not lean on the centrifuge.
- Use only rotors and accessories approved for this centrifuge. Exceptions to this rule are commercially available glass or plastic centrifuge tubes, provided they are approved for the speed or the RCF value of the rotor.
- Do not use rotors that show any signs of corrosion and or cracks.
- Do not touch the mechanical components of the rotor and do not make any changes to the mechanical components.
- Use only with rotors which have been properly installed. Follow the instructions on the Auto-Lock™ in section **Rotor Installation**.
- Use only with rotors which have been loaded properly. Follow the instructions given in the rotor manual.
- Never overload the rotor. Follow the instructions given in the rotor manual.
- Never start the centrifuge when the lid is open.
- Never open the lid until the rotor has come to a complete stop and this has been confirmed in the display.

- The lid emergency release may be used in emergencies only to recover the samples from the centrifuge, e.g. during a power failure (Refer to **Mechanical Emergency Door Release**).
- Never use the centrifuge if parts of its cover panels are damaged or missing.
- Do not touch the electronic components of the centrifuge or alter any electronic or mechanical components.
- Observe the safety instructions.

Pay attention to the following:

- **Location:** Well-ventilated environment, set-up on a level and rigid surface with adequate load-bearing capacity.
- **Rotor installation:** Make sure the rotor is locked properly into place before operating the centrifuge.
- When working with corrosive samples (salt solutions, acids, bases), the accessory parts and vessel have to be cleaned carefully.
- Always balance the samples.

Centrifuging hazardous substances:

- Do not centrifuge explosive or flammable materials or substances which could react violently with one another.
- The centrifuge is neither inert nor protected against explosion. Never use the centrifuge in an explosion-prone environment.
- Do not centrifuge toxic or radioactive materials or any pathogenic micro-organisms without suitable safety precautions.

When centrifuging microbiological samples from the Risk Group II (according to the Bio-safety Manual of the World Health Organization WHO), aerosol-tight biological seals have to be used.

For materials in a higher risk group, extra safety measures have to be taken.

- If toxins or pathogenic substances enters into the centrifuge or its parts, appropriate disinfection measures have to be taken (Refer to section **Disinfection**).
- Highly corrosive substances which can cause material damage and impair the mechanical stability of the rotor, should only be centrifuged in corresponding protective tubes.

IF A HAZARDOUS SITUATION OCCURS, TURN OFF THE POWER SUPPLY TO THE CENTRIFUGE AND LEAVE THE AREA IMMEDIATELY.



This symbol refers to general hazards.

CAUTION: Means that material damage could occur.

WARNING: Means that injuries or material damage or contamination could occur.



This symbol refers to biological hazards.

Observe the information contained in the instruction manual to keep yourself and your environment safe.

Introduction and Description

Characteristics

Several rotors with a wide range of tubes can be used.

The set speed is reached within seconds. The maintenance-free induction motor ensures quiet and low vibration operation even at high speeds, and guarantees a very long lifetime.

The user-friendly control panel makes it easy to preset the speed, RCF value, running time, temperature, and running profile (acceleration and braking curves). You can choose between the display of speed and RCF or the entry mode.

These settings can be changed even while the centrifuge is running.

With the help of the PULSE key , you can also centrifuge a sample for just a few seconds, if necessary.

The Fisherbrand GT 2 / 2R Centrifuge is equipped with various safety features:

- The housing and rotor chamber consist of steel plate and the interior is made of armour steel, while the front panel is made of high-impact resistant plastic.
- The lid is equipped with a view port and a lock.
- The lid of the centrifuge can only be opened while the centrifuge is switched ON and the rotor has come to a complete stop. The centrifuge cannot be started until the lid is closed properly.
- The integrated rotor detection system ensure that no inadmissible speed settings can be preselected.
- Electronic imbalance recognition
- Lid emergency release: For emergencies only, e.g. during power failures (Refer to the section **Mechanical Emergency Door Release**)

Technical Data

The technical data of the Fisherbrand GT 2 / 2R Centrifuge is listed in the following table:

Feature	Values	
Environmental conditions	Use in interior spaces	
	Altitudes of up to 2000 m above sea level	
	Max. relative humidity 80 % up to 31 °C; decreasing linearly up to 50 % relative humidity at 40 °C.	
Permissible ambient temperature	+2 °C to +35 °C	+2 °C to +35 °C
Overvoltage category	II	II
Pollution degree	2	2
Heat dissipation	Refrigerated	Ventilated
	230 V	230 V
	4 778 BTU/h	3 447 BTU/h
IP	20	20
Running time	Unlimited	Unlimited
Max Speed n_{\max}	15 200 rpm (depending on the rotor)	15 200 rpm (depending on the rotor)
Min Speed n_{\min}	300 rpm	300 rpm

Feature	Values	
Maximum RCF value at n_{\max}	25 830 x g	25 830 x g
Maximum kinetic energy	62.5 kJ	51.7 kJ
Noise level at maximum speed	< 63 dB (A)	< 63 dB (A)
Temperature setting range	-10 °C to +40 °C	
Dimensions	Refrigerated	Ventilated
Height	360 mm	360 mm
Height with lid open	870 mm	870 mm
Width	623 mm	440 mm
Depth	605 mm	605 mm
Table top height	310 mm	310 mm
Weight without rotor	91.5 kg	57.5 kg

Directives, Standards and Guidelines

Tension / Frequency	Directives	Produced and inspected according to the following standards and guidelines
220-230 V 50 / 60 Hz	2006/42/EC Machinery	EN 61010-1, 2 nd Edition EN 61010-2-020, 2 nd Edition EN 61326-1 EN ISO 14971 EN ISO 9001
	2014/35/EU Low Voltage (Protective Goals)	
	2014/30/EC Electromagnetic Compatibility (EMC)	
	2011/65/EC RoHS	
	Directive on the Restriction of the use of certain Hazardous Substances in electrical and electronic equipment	

Functions and Features

The following table gives an overview of the important functional and performance characteristics of the Fisherbrand GT 2 / 2R Centrifuge.

Component / Function	Description / Features
Structure / Housing	Galvanized steel chassis with armoured plating
Chamber	Stainless steel
Drive	Induction drive without carbon brushes
Keys and display	Easy-to-clean keypad and display surface
Controls	Microprocessor-controlled
Internal memory	The most recent data is saved

Component / Function	Description / Features
Functions	RCF-selection, temperature control, pretemp with cooling equipped devices
Acceleration / braking profiles	9 acceleration and 10 braking curves
Rotor recognition	Automatic
Imbalance recognition	Electronic, contingent on rotor and speed
Lid lock	Automatic lid closing and locking starting from an initial hold position

Mains Supply

The following table contains an overview of the electrical connection data for the Fisherbrand GT 2 / 2R Centrifuge. Consider the following data when selecting the mains connection socket.

Type	Mains Voltage	Frequency	Rated Current	Power Consumption	Equipment Fuse	Building Fuse
Refrigerated	230 V	50 / 60 Hz	8 A	1 400 W	15 AT	16 AT
Ventilated	230 V	50 / 60 Hz	6 A	1 010 W	15 AT	16 AT

*Contact an authorized customer service representative for running the centrifuge at 60 Hz.

Refrigerant

Order no.	Centrifuge	Refrigerant	Quantity	Pressure	GWP	CO ₂ e
75004203	Fisherbrand GT2R	R-134a	0.28 kg	21 bar	1 430	0.40 t

Refrigerant contains fluorinated greenhouse gases in a hermetically sealed system.

Rotor Selection

Various rotors are available to choose from the following:

TX-400	75003629
with round buckets	75003655
TX-200	75003658
with round buckets	75003659
BIOShield™ 720	75003621
M-20	75003624
Microliter™ 30x2 sealed	75003652
CLINIConic™ 30x15	75003623
8x50 sealed	75003694
FIBERLite™ F15-6x100	75003698
HIGHConic™ II	75003620
TX-1000	75003017
TX-750	75003180
BIOShield™ 1000 A	75003182
M-20	75003624

The technical data of the rotors and the corresponding adapters and reduction sleeves for various commercially available containers can be found in the corresponding rotor operating manuals.

For more information visit our website at:
fishersci.com

Before Use

Before Setting up

1. Check the centrifuge and the packaging for any shipping damage. Inform Fisher Scientific Customer Service immediately if any damage is discovered.
2. Remove the packaging.
3. Check the order for completeness (Refer to the section **Scope of Supply**). If the order is incomplete, contact Fisher Scientific.

Transporting the Centrifuge

- Due to the weight (Refer to the section **Technical Data**), the centrifuge should be carried by several people.
- Always lift the centrifuge at both sides.

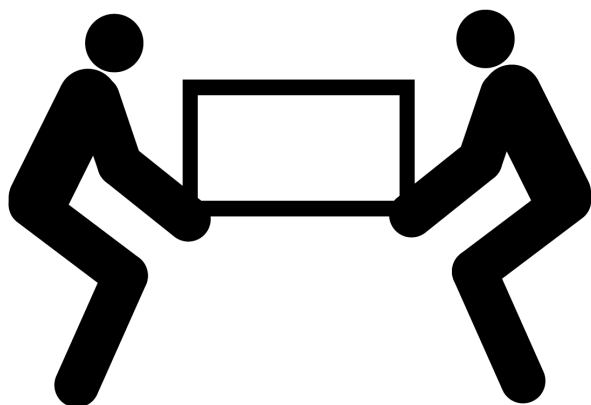

Figure 1. Lifting the centrifuge at both sides.

- The centrifuge can be damaged by impacts.
- Transport the centrifuge upright and if at all possible in its packaging.



WARNING: Always lift the centrifuge on both sides. Never lift the centrifuge by its front or the back panel.

Always remove the rotor before moving the centrifuge.

Location

The centrifuge should only be operated indoors.

The set-up location must fulfill the following requirements:

- A safety zone of at least 30 cm must be maintained around the centrifuge.
People and hazardous substances must be kept out of the safety zone while centrifuging.
- The supporting structure must be stable and free of resonance, for example, a level laboratory bench.
- The supporting structure must be suitable for horizontal setup of the centrifuge.
- The centrifuge should not be exposed to heat and strong sunlight.



WARNING: UV rays reduce the stability of plastics.

Do not subject the centrifuge, rotors and plastic accessories to direct sunlight.

- The set-up location must be well ventilated at all times.

Aligning the Centrifuge

The horizontal alignment of the centrifuge must be checked every time after moving it to a different location.

The supporting structure must be suitable for horizontal setup of the centrifuge.



CAUTION: If the centrifuge is not level, imbalances can occur and the centrifuge can be damaged.

Do not place anything under the feet to level the centrifuge.

Mains Connection

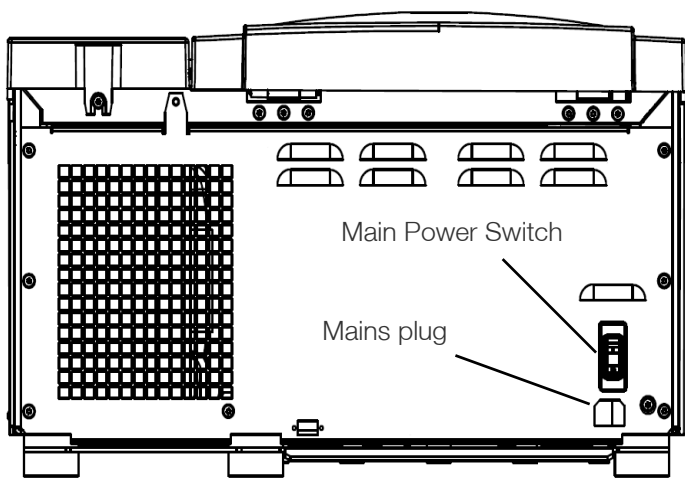

Figure 2. Mains Connection

1. Turn off the power supply switch ON the back (press "0").
2. Plug the centrifuge into grounded electrical sockets only.
3. Check whether the cable complies with the safety standards of your country.
4. Make sure that the voltage and frequency correspond to the figures on the rating plate.
5. Establish the connection to the power supply with the connecting cable.

Storage

- Before storing the centrifuge and the accessories, it must be cleaned and if necessary disinfected and decontaminated.
- Store the centrifuge in a clean, dust-free location.
- Ensure to place the centrifuge on its feet.
- Avoid direct sunlight.

Control Panel





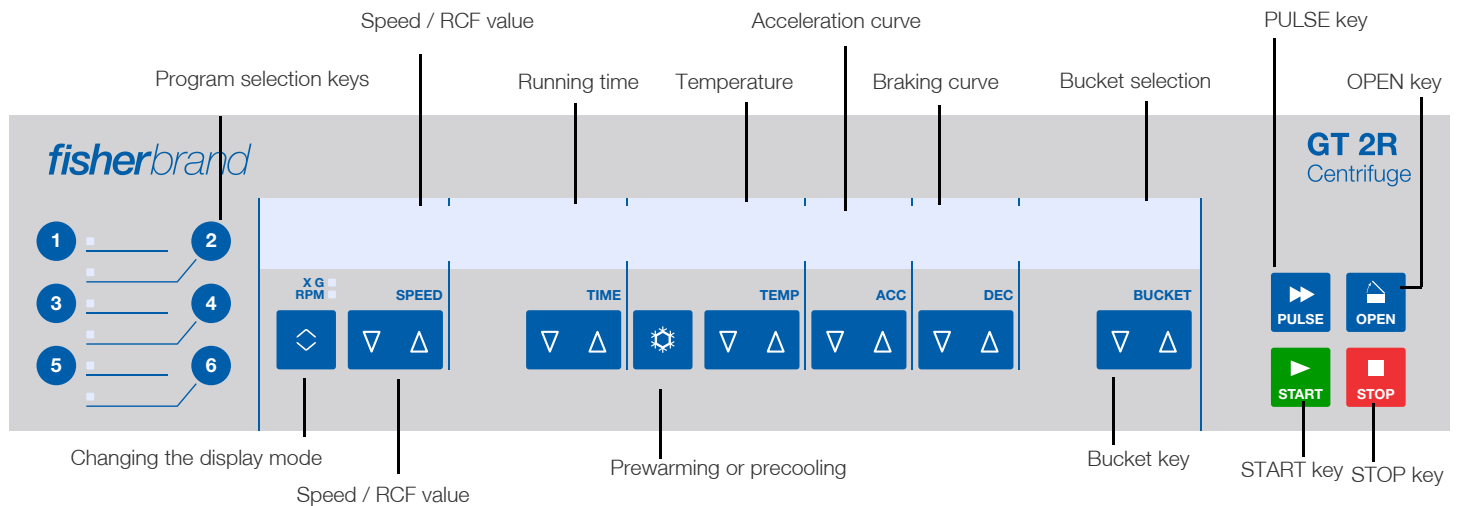

Control Panel

The control panel contains the keys and displays of the centrifuge (only the power switch is located on the back of the device). All parameters can be selected and changed during operation.



Keys

The keys allow user intervention for controlling the operating mode as follows:

Key	Display Contents
 Start	Normal start of the centrifuge
 Stop	End run manually
 Open Lid	Automatic release (possible only when device is switched ON). Emergency release (see Mechanical Emergency Door Release)
 Pulse	By pressing the PULSE key the centrifuge starts immediately and accelerates up to the end speed. Releasing the key initiates a stopping process at the highest braking curves
 Change Value	Use the arrow keys in order to modify the displayed value
 Snow Symbol	Press the snow symbol key for prewarming or precooling the centrifuge
 Changing the display mode	Use the Change key to change the display mode. (Speed / RCF Value)

Operation

Switch ON Centrifuge

1. Turn on the power switch ON the back of the device.
The device performs a self-check of its software.
 - a. When the centrifuge lid is closed the following display shows:

0 0:00 -10 9 9 3608

The speed and time displays read 0. The temperature indicator displays the current temperature inside the rotor chamber. The preset acceleration and braking curves and the selected bucket are also displayed.

- b. When the centrifuge lid is open the following display shows:

15000 1:30 -10 9 9 3608

The speed and time displays show the preset values. The temperature indicator displays the current temperature inside the rotor chamber. The preset acceleration, braking curves and the selected bucket are also displayed.

Lid Opening

1. Press the OPEN key .



WARNING: Do not reach into the crack between the lid and the housing. The lid is drawn shut automatically.

Use the emergency release only for malfunctions and power failures (Refer to the section **Mechanical Emergency Door Release**).

Close Lid

Close the lid by pressing down on it lightly in the middle or on both sides of it. One lock closes the lid completely.



WARNING: Do not reach into the crack between the lid and the housing. The lid is drawn shut automatically.

Note: The lid should audibly click into place.

Rotor Installation

The approved rotors for the Fisherbrand GT 2 / 2R Centrifuge are listed in section **Rotor Selection**. Use only the rotors and accessories from this list in the centrifuge.



CAUTION: Unapproved or incorrectly combined accessories can cause serious damage to the centrifuge.

The centrifuge is equipped with an Auto-Lock locking system.

This system is used to automatically lock the rotor to the centrifuge spindle. The rotor does not have to be bolted on to the centrifuge spindle.

Proceed as follows:

1. Open the lid of the centrifuge and if necessary remove any dust, foreign objects or residue from the chamber. Auto-Lock and o-ring must be clean and undamaged.

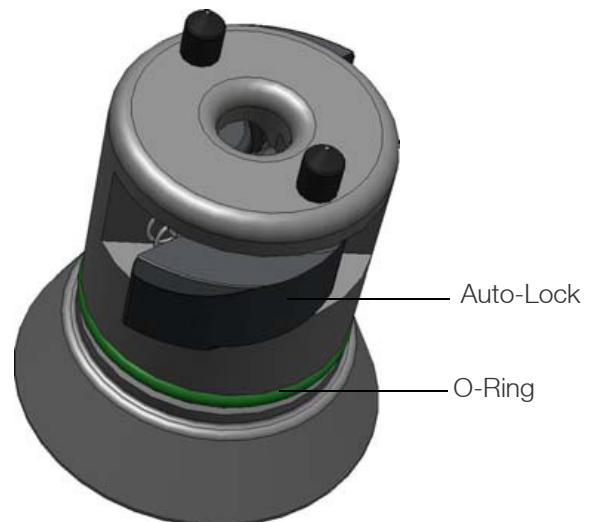

Figure 3. Auto-Lock

2. Place the rotor over the centrifuge spindle and let it slide slowly down the centrifuge spindle. The rotor clicks automatically into place.



CAUTION: Do not force the rotor onto the centrifuge spindle.

If the rotor is very light, then it may be necessary to press it onto the centrifuge spindle with pressure.

3. Check if the rotor is properly installed by lifting it slightly on the handle. If the rotor can be pulled up, then it must be reclamped to the centrifuge spindle.



WARNING: If the rotor cannot be properly locked in place after several attempts, then the Auto-Lock is defective and you are not permitted to operate the rotor.

Check for any damage to the rotor: Damaged rotors must not be used.

Keep the centrifuge spindle area of the rotor clear of objects.



CAUTION: Check that the rotor is properly locked on the centrifuge spindle before each use by pulling it at its handle.

4. If available close the rotor with the rotor lid.



Be sure to check all sealings before starting any aerosol-tight applications.

See information in the rotor instruction manual.

5. Close the centrifuge lid.

Entering Parameters

The Fisherbrand GT 2 / 2R Centrifuge offers you a total of 9 acceleration and 10 braking curves with which samples and gradients can be centrifuged.

After the centrifuge is turned on, the last running profile selected is shown.

Acceleration curve

1. Press the key  below the ACC display in order to open the acceleration profile selection menu.

The display shows the message "Set acceleration".

Set acceleration 9

2. Select the profile by pressing the key , until the desired acceleration curve shows.

Braking curve

1. Press the key  below the DEC display in order to open the braking curve selection menu.

The display shows the message "Set deceleration"

Set deceleration 9

2. Select the profile by pressing the key , until the desired braking curve is shown.

Preselecting Speed / RCF

1. Press the key  below the "SPEED" display in order to open the speed / RCF value menu.

The display shows the RPM or the RCF value depending on the display setting. Press the CHANGE key  to toggle between the two modes.

24400 xg Set RCF

15000 rpm Set speed

2. Enter the desired value by pressing the key  repeatedly, until the desired value shows.

Note: If an extremely low RCF value has been selected, it will be corrected automatically if the resulting speed is less than 300 rpm.

Explanation of RCF Value

The relative centrifugal force is given as a multiple of the force of gravity g. It is a unitless numerical value which is used to compare the separation or sedimentation capacity of various devices, since it is independent of the type of device. Only the centrifuging radius and the speed come into play in it:

$$RCF = 11.18 \times \left(\frac{n}{1000} \right)^2 \times r$$

r = centrifuging radius in cm

n = Rotational speed in rpm

The maximum RCF value is related to the maximum radius of the tube opening.

Remember that this value is reduced depending on the tubes and adapters used.

This can be accounted for in the calculation above if required.

Running Time Preselection

1. Press the key  below the TIME display in order to open the runtime selection menu.

The display shows the message "Set time".

Enter the desired runtime in H.mm.

0.14 Set time H.mm

2. Enter the desired value by pressing the key  repeatedly, until the desired value shows.

Continuous operation

1. Press the START key . During continuous operation, the centrifuge will continue running until you stop manually.

HOLD Non-Stop mode

Preselecting the temperature

You can preselect temperatures between -10 °C and +40 °C.

To set the temperature, proceed as follows:

1. Press the key  below the TEMPERATURE display in order to open the temperature selection menu.

The display shows "Set temp":

Set temp -10°C

2. Enter the desired value by pressing the key  repeatedly, until the desired value shows.

Prewarming or precooling the centrifuge

For setting the pretemp value for the centrifuge proceed as follows:

1. Press the key  in order to open the temperature selection menu.

The display shows the message "Set PreTemp".

Set PreTemp -10°C

2. Enter the desired value by pressing the key  repeatedly, until the desired value shows.

PreTemp -10°C

3. The display shows:

Press start 24°C PreWarm

The display shows the current temperature inside the rotor chamber.

4. Press the START key .

15000 4° PreCool

The rotor chamber is cooled down or heated up to the preset temperature.

15000 PT 4° Ready

5. Press the STOP key . The display shows the current temperature inside the rotor chamber.

Saving programs

1. Enter the program parameters.
2. Press any of the program store keys for 4 seconds.

Centrifugation

Once the rotor has been properly installed, the main switch is turned on and the lid is closed, you can start centrifuging.

Starting centrifuge program

Press the START key  on the control panel. The centrifuge accelerates to the pre-set speed with the time display active.

If the speed setting is higher than the maximum permissible speed or RCF-value for the particular rotor, the display will show the message max. XXXX rpm once the centrifuge has been started.

Within 15 seconds, you can apply this value by pressing the START key  again, and the centrifuging program will continue. Otherwise the centrifuge will stop and you must enter a valid number.

You cannot open the lid as long as the centrifuge is running.

Imbalance indicator

If a load is imbalanced, this will be indicated at speed higher than approximately 300 rpm by the message "Imbalanced load".

The run will terminate.

Check the loading and start the centrifuge once again. See information on proper loading in the rotor instruction manual. For information on troubleshooting, refer to the section **Troubleshooting by User**.

Stopping the centrifugation program



With preset running time

Usually the running time is preset and you only have to wait until the centrifuge stops automatically when the preset time limit expires.

As soon as the speed drops to zero, the message END will appear in the display. By pressing the OPEN key , you can open the lid and remove the centrifuge material.

You can also stop the centrifuging program manually at any time by pressing the STOP key .

Continuous operation

If you select continuous operation (Refer to the section **Continuous operation**), you must stop the centrifuge manually. Press the STOP key  on the control panel. The centrifuge will be decelerated at the designated rate. The message "END" will illuminate, and after pressing the OPEN key , the lid will open and you can remove the centrifuged material.

Temperature Adaptation during Standstill

The temperature cannot be adapted until the rotor is positively identified; the speed display will then show END.

When the rotor is not recognized (lid closed and START key  not yet pressed, speed display "0"), the centrifuge responds by ensuring that the sample cannot freeze regardless of the rotor being used.

Short-term Centrifugation

For short-term centrifuging, the Fisherbrand GT 2 / 2R Centrifuge has a PULSE- function.

By holding down the PULSE key , spinning will start and continue until the key is let go.

The centrifuge accelerates and brakes at maximum power. Any rpm or RCF entered beforehand is overridden.

Note: The centrifuge accelerates to maximum speed, regardless of which rotor is installed.

Check carefully whether you must maintain a certain speed for your application.

During the acceleration process, time is counted forward in seconds. The reading is displayed until the centrifuge lid is opened.

Removing the Rotor

To remove the rotor, proceed as follows:

1. Open the centrifuge lid.
2. Grab the rotor handle with both hands and press against the green Auto-Lock key. At the same time, pull the rotor directly upwards with both hands and remove it from the centrifuge spindle. Make sure not to tilt the rotor while doing this.



Figure 4. Removing the rotor

Aerosol-Tight Rotors

When using an aerosol tight lid the rotor can only be removed with the lid closed. This is to protect you and the samples.



CAUTION: Rotors supplied with a lid for aerosol-tight applications come with a mandrel, which belongs to the Auto-Lock. Be sure not to place the lid onto this mandrel to prevent it from being damaged.

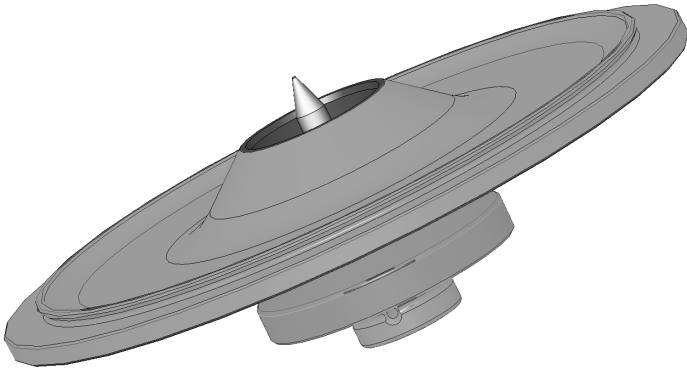

Figure 5. Auto-Lock lid for aerosol-tight rotors



WARNING: Mind the Auto-Lock mandrel inside the lid. Do not touch the mandrel.

Aligning the Centrifuge

To turn off the centrifuge put the mains switch to "0"

System Menu

- Use   below the bucket selection in order to navigate within the system menu points.

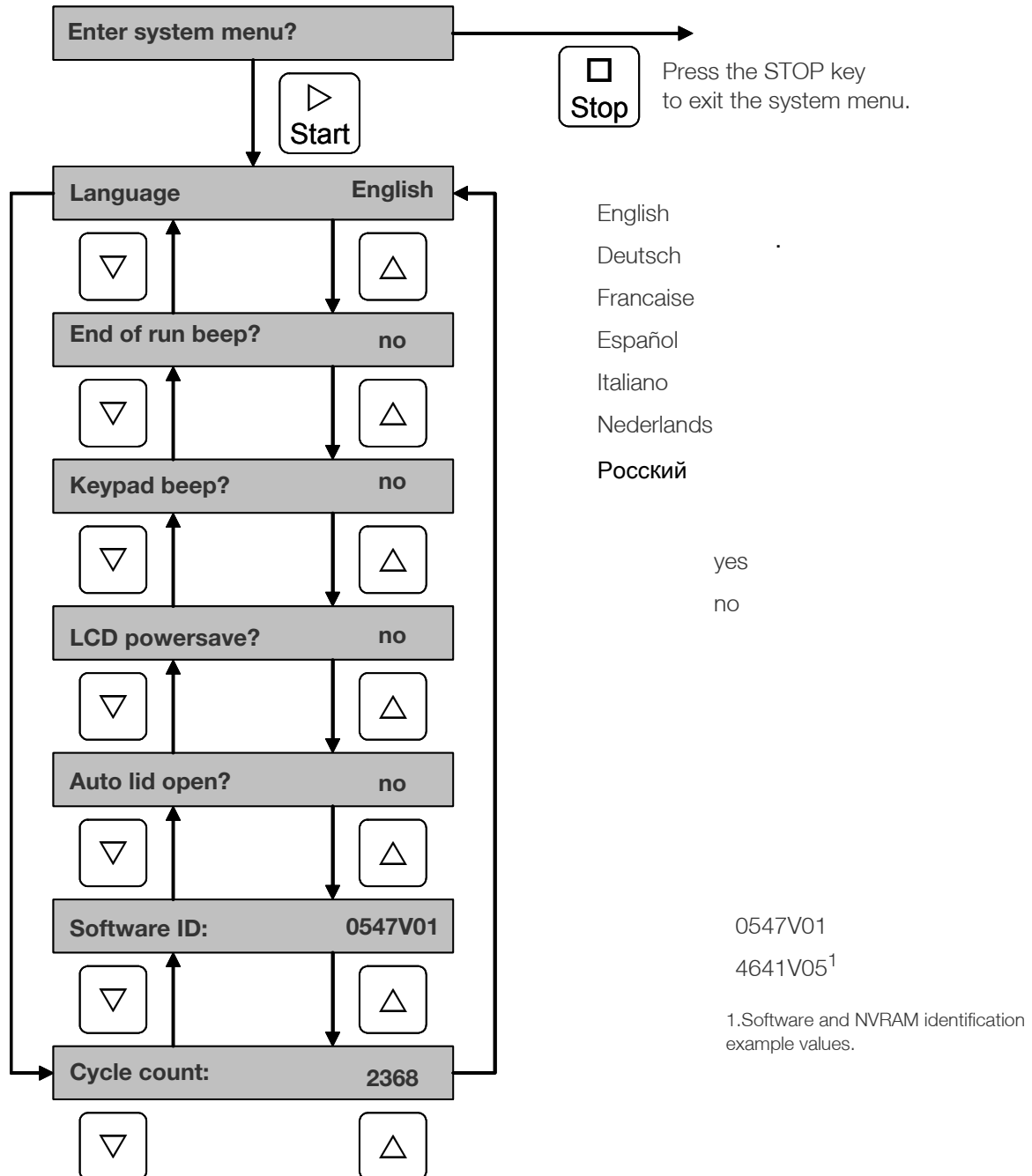





Description

Enter System Menu

To enter the system menu hold down any of the keys when switching the centrifuge ON.



Change the selection by pressing the keys  .



Use the keys   below the speed display in order to navigate through the system menu.

Use the keys   below the bucket selection in order to navigate within the system menu points.

Press the STOP key  to quit the system menu.





Language



Use the keys   below the bucket selection in order to change the language in the display until the desired language appears in the display.

Use the keys   below the speed display in order to navigate through the system menu.

Press the STOP key  to quit the system menu.





End of Run Beep



Use the keys   below the bucket selection until it says YES in the display if the centrifuge should make beep after the run. Otherwise use the keys   below the bucket selection until it says NO.

Use the keys   below the speed display in order to navigate through the system menu.

Press the STOP key  to quit the system menu.





Keypad Beep



Use the keys   below the bucket selection until it says YES in the display if the centrifuge should make beep when pressing any key. Otherwise use the keys   below the bucket selection until it says NO.

Use the keys   below the speed display in order to navigate through the system menu.

Press the STOP key  to quit the system menu.





LCD Powersave



Use the keys   below the bucket selection until it says YES in the display if the centrifuge should enter a powersave mode after the run. Otherwise use the keys   below the bucket selection until it says NO.

Use the keys   below the speed display in order to navigate through the system menu.

Press the STOP key  to quit the system menu.

Auto Lid Open



Use the keys   below the bucket selection until it says YES in the display if the centrifuge should open after the run. Otherwise use the keys   below the bucket selection until it says NO.

Use the keys   below the speed display in order to navigate through the system menu.

Press the STOP key  to quit the system menu.

Software ID



Here you find the current software version.

Use the keys   below the speed display in order to navigate through the system menu.

Press the STOP key  to quit the system menu.

Cycle Count

Here you find the current numbers of cycles.

Use the keys   below the speed display in order to navigate through the system menu.

Press the STOP key  to quit the system menu.

Maintenance and Care

After cleaning the centrifuge and accessories, treat the entire surface of aluminum parts with corrosion protection oil (70009824). Also treat the cavities with oil.

Cleaning Intervals

For the sake of personal, environmental, and material protection, it is your duty to clean and if necessary disinfect the centrifuge on a regular basis.

Maintenance	Recommended interval
Clean rotor chamber	Daily or when polluted
Clean rotor	Daily or when polluted
Accessories	Daily or when polluted
Cabinet	Once per month
Ventilation holes	Every six months



CAUTION: Refrain from using any other cleaning or decontamination procedure than those recommended here, if you are not entirely sure that the intended procedure is safe for the equipment.

Use only approved cleansers.

If in doubt, contact Fisher Scientific.

Cleaning

When cleaning centrifuge:

- Use warm water with a neutral solvent.
- Never use caustic cleaning agents such as soap suds, phosphoric acid, bleaching solutions or scrubbing powder.
- Rinse the cavities thoroughly.
- Use a soft brush without metal bristles to remove stubborn residue.
- Afterwards rinse with distilled water.
- Place the rotors on a plastic grate with their cavities pointing down.

- If drying boxes are used, the temperature must never exceed 50 °C, since higher temperatures could damage the material and shorten the lifetime of the parts.
- Use only disinfectants with a pH of 6 to 8.
- Dry aluminum parts off with a soft cloth.
- Store the aluminum parts at room temperature or in a cold-storage room with the cavities pointing down.



CAUTION: Before using any cleaning or decontamination methods except those recommended by the manufacturer, users should check with the manufacturer that the proposed method will not damage the equipment.

Clean centrifuge and accessories as follows:

1. Open the centrifuge.
 2. Turn OFF the centrifuge.
 3. Pull out the power supply plug.
 4. Grasp the rotor with both hands and lift it vertically off the centrifuge spindle.
 5. Remove the centrifuge tubes and adapters.
 6. Use a neutral cleaning agent with a pH value between 6 and 8 for cleaning.
 7. Dry all of the rotors and accessories after cleaning with a cloth or in a warm air cabinet at a maximum temperature of 50 °C.
- Tread the bold of the swing out rotor with bold grease (75003786).



CAUTION: When cleaning, do not allow liquids, especially organic solvents, to get on the drive shaft or the bearings of the centrifuge.

Organic solvents break down the grease in the motor bearing. The drive shaft could freeze up.

After some applications there might be ice in the rotor chamber. Let the ice melt and drain it off. Clean the rotor chamber as described above.

Disinfection

Disinfect the centrifuge immediately when infectious material has spilled during centrifugation.



WARNING: Infectious material can get into the centrifuge when a tube breaks or as a result of spills. Keep in mind the risk of infection when touching the rotor and take all necessary precautions.

In case of contamination, make sure that others are not at risk.

Decontaminate the affected parts immediately.

Take other precautions if necessary.

The rotor chamber and the rotor should be treated preferably with a neutral disinfectant.



CAUTION: Before using any cleaning or decontamination methods except those recommended by the manufacturer, users should check with the manufacturer that the proposed method will not damage the equipment.

Observe the safety precautions and handling instructions for the cleaning agents used.

Contact the Service Department of Fisher Scientific for questions regarding the use of other disinfectants.

Disinfect the rotor and accessories as follows:

1. Open the centrifuge.
 2. Turn OFF the centrifuge.
 3. Pull out the power supply plug.
 4. Grasp the rotor with both hands and lift it vertically off the centrifuge spindle.
 5. Remove the centrifuge tubes and adaptors and dispose of them or disinfect them.
 6. Treat the rotor and accessories according to the instructions for the disinfectant (soak in solution). Adhere strictly to the given application terms.
 7. Be sure that disinfectant can drain off the rotor.
 8. Rinse the rotor and accessories thoroughly with water.
 9. Dispose of the disinfectant according to the applicable guidelines.
 10. Dry all of the rotors and accessories after cleaning with a cloth or in a warm air cabinet at a maximum temperature of 50 °C.
- Tread the bold of the swing out rotor with bold grease (75003786).

Decontamination

Decontaminate the centrifuge immediately whenever radioactive material has spilled during centrifugation.



WARNING: Radioactive material can get into the centrifuge when a tube breaks or as a result of spills. Keep in mind the risk of contamination when touching the rotor and take all necessary precautions.

In case of contamination, make sure that others are not put at risk.

Decontaminate the affected parts immediately.

Take other precautions if necessary.



CAUTION: Before using any cleaning or decontamination methods except those recommended by the manufacturer, users should check with the manufacturer that the proposed method will not damage the equipment.

For general radioactive decontamination use a solution of equal parts of 70 % ethanol, 10 % SDS and water.

1. Open the centrifuge.
 2. Turn OFF the centrifuge.
 3. Pull out the power supply plug.
 4. Grasp the rotor with both hands and lift it vertically off the centrifuge spindle.
 5. Remove the centrifuge tubes and adaptors and dispose of them or decontaminate them.
 6. Rinse the rotor first with ethanol and then with de-ionized water.
 7. Adhere strictly to the given application terms.
 8. Be sure the decontamination solution can drain off the rotor.
 9. Rinse the rotor and accessories thoroughly with water.
 10. Dispose of the decontamination solution according to the applicable guidelines.
 11. Dry all of the rotors and accessories after cleaning with a cloth or in a warm air cabinet at a maximum temperature of 50 °C.
- Tread the bold of the swing out rotor with bold grease (75003786).

Autoclaving

- Before autoclaving clean rotor and accessories as described above.
- Place the rotor on a flat surface.
- Rotors and adapter can be autoclaved at 121 °C.
- The maximum permissible autoclave cycle is 20 minutes at 121 °C.

Note: No chemical additives are permitted in the steam.



CAUTION: Never exceed the permitted temperature and duration when autoclaving.

If the rotor shows signs of corrosion or wear, it must be replaced.

Maintenance and repair Services

The manufacturer recommends having the centrifuge and accessories serviced once in a year by an authorized service technician. The service technicians check the following:

- The electrical equipment
- The suitability of the set-up site
- The lid lock and the safety system
- The rotor
- The fixation of the rotor and the drive shaft

Unity™ Lab Services offers inspection and service contracts for this work. The cost of any necessary repairs are covered under the warranty. Purchase a service contract to cover any services after the warranty has expired.

This is only valid if the centrifuge has only been maintained by an authorized service technician.

Troubleshooting

Mechanical Emergency Door Release

Reconnect the centrifuge once the power has been restored. Switch ON the centrifuge. Press the OPEN key  to have the door locks operative again.

During a power failure, you will not be able to open the centrifuge lid with the regular electric lid release. A mechanical override is provided to allow sample recovery in the case of an emergency. However, this should be used only in emergencies and after the rotor has come to a complete stop.



WARNING: The rotor can still be spinning at high speed. If touched, it can cause serious injuries.

Always wait for few minutes until the rotor has come to a stop without braking. The brake does not work when there is no current. The braking process lasts much longer than usual.

Proceed as follows:

1. Make sure the rotor has stopped (view port in the lid).



WARNING: Never use your hand or other tools to brake the rotor.

2. Pull out the power supply plug.
3. Pry out the white plastic plug (available on the left side of housing) from the side plate with a screwdriver or a knife.

Pull the release cord attached to it to trigger the mechanical lid release. The lid will open and the samples can be removed.

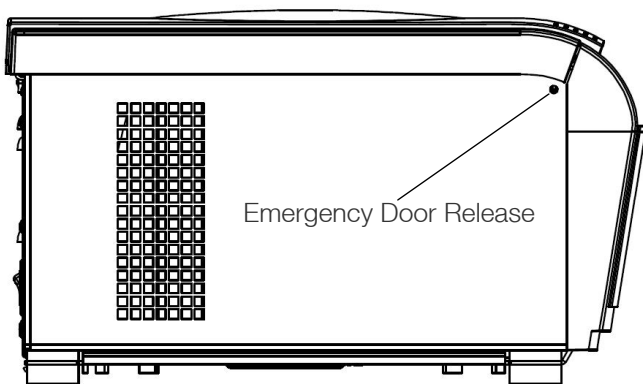

Figure 6. Emergency Door Release

4. Push the cord back into the centrifuge and mount the plug.

Troubleshooting by User



If problems occur other than those listed in this table, the authorized customer service representative must be contacted.

Failure message	Problem with centrifuge	Possible causes and cures
Overtemperature	The centrifuge cannot be operated. The run does not start or the centrifuge runs down without being braked.	Overheating in chamber. Check the function of the refrigeration unit. Clean the air inlet for the condenser. Restart the centrifuge. If an error message appears again, contact Unity Lab Services.
Incorrect bucket ID	The centrifuge cannot be operated. The run does not start or the centrifuge runs down without being braked.	Bucket code is undefined for the rotor detected, check the set points for the given bucket code. It is permitted to use the current bucket in the rotor currently mounted. Restart the centrifuge. If an error message appears again, contact Unity Lab Services.
Unapproved rotor	The centrifuge cannot be operated. The run does not start or the centrifuge runs down without being braked.	Rotor code is not in the rotor table. It is permitted to use the rotor currently mounted in this device. Restart the centrifuge. If an error message appears again, contact Unity Lab Services.
Rotor ID failure	The centrifuge cannot be operated. The run does not start or the centrifuge runs down without being braked.	The rotor could not be identified. Check to see if the rotor is properly installed. Restart the centrifuge. If an error message appears again, contact Unity Lab Services.
Lid blocked	Centrifuge does not open.	Restart the centrifuge. The emergency lid release enables you to retrieve your samples. If an error message appears again, contact Unity Lab Services.
Motor overtemp	The centrifuge cannot be operated. The run does not start or the centrifuge runs down without being braked.	Restart the centrifuge. If an error message appears again, contact Unity Lab Services.
PCB overtemp	The centrifuge cannot be operated. The run does not start or the centrifuge runs down without being braked.	Restart the centrifuge. If an error message appears again, contact Unity Lab Services.

Failure message	Problem with centrifuge	Possible causes and cures
Emergency release	The centrifuge cannot be operated. The run does not start or the centrifuge runs down without being braked.	The lid opens while the device is running. Close the lid and restart the centrifuge. If an error message appears again, contact Unity Lab Services.
Imbalanced load	The centrifuge cannot be operated. The run does not start or the centrifuge runs down without being braked.	Imbalance detected. Check the load placed in the rotor. Check that the rotor cross bolts are well greased. Restart the centrifuge. If an error message appears again, contact Unity Lab Services.
Check Set Speed	The centrifuge cannot be operated. The run does not start or the centrifuge runs down without being braked.	The set point speed is higher than the maximum rotor speed. Correct the value. Restart the centrifuge. If an error message appears again, contact Unity Lab Services.
E-01 - E-12	The centrifuge cannot be operated. The run does not start or the centrifuge runs down without being braked.	Error during the self-test of the centrifuge program and the electronics. Restart the centrifuge. If an error message appears again, contact Unity Lab Services.
E-13	The centrifuge cannot be operated. The run does not start or the centrifuge runs down without being braked.	The check sum in the data memory is incorrect. The software corrects errors automatically. Check the values of the set point settings, etc. Restart the centrifuge. If an error message appears again, contact Unity Lab Services.
E-15-E-16	Temperature sensor broken / controller defective	Malfunction in the temperature detection. Restart the centrifuge. If an error message appears again, contact Unity Lab Services.
E-17	Speed for rotor detection exceeded	Restart the centrifuge. If an error message appears again, contact Unity Lab Services.
E-21-E-22	The centrifuge cannot be operated. The run does not start or the centrifuge runs down without being braked.	The rotor could not be identified. Check to see if the rotor is properly installed. Restart the centrifuge. If an error message appears again, contact Unity Lab Services.

Failure message	Problem with centrifuge	Possible causes and cures
E-23	The centrifuge cannot be operated. The run does not start or the centrifuge runs down without being braked.	The speed control measurement returned a different result. Restart the centrifuge. If an error message appears again, contact Unity Lab Services.
E-25-E-27	The centrifuge cannot be operated. The run does not start or the centrifuge runs down without being braked.	Time has expired for the lid lock drive while opening the lid. Restart the centrifuge. If an error message appears again, contact Unity Lab Services.
E-28	The centrifuge cannot be operated. The run does not start or the centrifuge runs down without being braked.	Error during the self-test of the centrifuge program and the electronics. Restart the centrifuge. If an error message appears again, contact Unity Lab Services.
E-29	The centrifuge cannot be operated. The run does not start.	Check whether you selected the right bucket. Is it easy to turn the rotor when the lid is open? Does the rotor rub against the device? Restart the centrifuge. If an error message appears again, contact Unity Lab Services.
E-30	The centrifuge cannot be operated. The run does not start or the centrifuge runs down without being braked.	Restart the centrifuge. If an error message appears again, contact Unity Lab Services.
E-33	The centrifuge cannot be operated. The run does not start or the centrifuge runs down without being braked.	Overpressure in the refrigeration unit. Clean the air inlet for the condenser. Restart the centrifuge. If an error message appears again, contact Unity Lab Services.
E-34-E-36	The centrifuge cannot be operated. The run does not start or the centrifuge runs down without being braked.	Error during the self-test of the centrifuge program and the electronics. Restart the centrifuge. If an error message appears again, contact Unity Lab Services.

Failure message	Problem with centrifuge	Possible causes and cures
E-40	The centrifuge cannot be operated. The run does not start or the centrifuge runs down without being braked.	The centrifuge accelerates too slowly. Check whether you selected the right bucket. Check whether you selected the right bucket. Is it easy to turn the rotor when the lid is open? Does the rotor rub against the device? Restart the centrifuge. If an error message appears again, contact Unity Lab Services.
E-41-E-74	The centrifuge cannot be operated. The run does not start or the centrifuge runs down without being braked.	Error during the self-test of the centrifuge program and the electronics. Restart the centrifuge. If an error message appears again, contact Unity Lab Services.



When to Contact Customer Service

If you need to contact customer service, provide the order no. and the serial no. of your device. This information can be found on the back near the inlet for the power supply cable.

To identify the software version, proceed as follows:

1. Hold down any of the keys and then switch ON the centrifuge.

You enter the system menu.

2. Press the START key .
3. Press the  key, until the following message is displayed:

Software ID: XXXXXXXXXX

4. Communicate the software version to the service technician.

Chemical Compatibility Chart

CHEMICAL	MATERIAL ALUMINUM	ANODIC COATING for ALUMINUM	BUNA N	CELLULOSE ACETATE BUTYRATE	POLYURETHANE ROTOR PAINT	COMPOSITE Carbon Fiber/Epoxy	DELRIN™	ETHYLENE PROPYLENE	GLASS	NEOPRENE	NORYL	NYLON™	PET*, POLYCLEAR™, POLYALLOMER	POLYCARBONATE	POLYESTER, GLASS THERMOSET	POLYETHERIMIDE	POLYTRHYLENE	POLYPROPYLENE	POLYSULFONE	POLYVINYL CHLORIDE	RULON A™, TEFLON™	SILICONE RUBBER	STAINLESS STEEL	TITANIUM	TYGON™	VITON™	
2-mercaptoethanol	S	S	U	-	S	M	S	-	S	U	S	S	U	S	S	-	S	S	S	S	U	S	S	S	S	S	
Acetaldehyde	S	-	U	U	-	-	-	M	-	U	-	-	-	M	U	U	U	M	M	-	M	S	U	-	S	-	U
Acetone	M	S	U	U	S	U	M	S	S	U	U	S	U	S	U	U	S	S	U	U	S	M	M	S	U	U	
Acetonitrile	S	S	U	-	S	M	S	-	S	S	U	S	U	M	U	U	-	S	M	U	U	S	S	S	S	U	
Alconox	U	U	S	-	S	S	S	-	S	S	S	S	S	S	M	S	S	S	S	S	S	S	S	S	S	U	
Allyl Alcohol	-	-	-	U	-	-	S	-	-	-	-	S	-	S	S	M	S	S	S	-	M	S	-	-	S	-	
Aluminum Chloride	U	U	S	S	S	S	U	S	S	S	S	M	S	S	S	-	S	S	S	S	S	M	U	U	S	S	
Formic Acid (100 %)	-	S	M	U	-	-	U	-	-	-	-	U	-	S	M	U	U	S	S	-	U	S	-	U	S	-	
Ammonium Acetate	S	S	U	-	S	S	S	-	S	S	S	S	S	S	S	U	-	S	S	S	S	S	S	S	S	S	
Ammonium Carbonate	M	S	U	S	S	S	S	S	S	S	S	S	S	S	U	U	-	S	S	S	S	S	S	M	S	S	
Ammonium Hydroxide (10 %)	U	U	S	U	S	S	M	S	S	S	S	S	-	S	U	M	S	S	S	S	S	S	S	S	M	S	
Ammoniumhydroxid (28 %)	U	U	S	U	S	U	M	S	S	S	S	S	U	S	U	M	S	S	S	S	S	S	S	M	S		
Ammonium Hydroxide (conc.)	U	U	U	U	S	U	M	S	-	S	-	S	U	S	U	U	S	S	S	-	M	S	S	S	-	U	

Key

- S Satisfactory
- M Moderate attack, may be satisfactory for use in centrifuge depending on length of exposure, speed involved, etc.; suggest testing under actual conditions of use.
- U Unsatisfactory, not recommended.
- No data available. Because no organized chemical resistance data exists for materials under the stress of centrifugation, when in doubt we recommend pretesting sample lots. suggest testing, using sample to avoid loss of valuable material.

CHEMICAL	MATERIAL ALUMINUM	ANODIC COATING for ALUMINUM	BUNA N	CELLULOSE ACETATE BUTYRATE	POLYURETHANE ROTOR PAINT	COMPOSITE Carbon Fiber/Epoxy	DELIRIN™	ETHYLENE PROPYLENE	GLASS	NEOPRENE	NORYL	NYLON™	PET*, POLYCLEAR™, POLYALLOMER	POLYCARBONATE	POLYESTER, GLASS THERMOSET	POLYETHERIMIDE	POLYRTHYLENE	POLYPROPYLENE	POLYSULFONE	POLYVINYL CHLORIDE	RULON A™, TEFLON™	SILICONE RUBBER	STAINLESS STEEL	TITANIUM	TYGON™	VITON™	
Ammonium Phosphate	U	-	S	-	S	S	S	S	S	S	S	S	-	S	S	M	-	S	S	S	S	S	S	M	S	S	S
Ammonium Sulfate	U	M	S	-	S	S	U	S	S	S	S	S	S	S	S	-	S	S	S	S	S	S	S	U	S	S	U
Amyl Alcohol	S	-	M	U	-	-	S	S	-	M	-	S	-	M	S	S	S	S	M	-	-	-	U	-	S	-	M
Aniline	S	S	U	U	S	U	S	M	S	U	U	U	U	U	U	-	S	M	U	U	S	S	S	S	U	S	
Sodium Hydroxide (<1 %)	U	-	M	S	S	S	-	-	S	M	S	S	-	S	M	M	S	S	S	S	S	S	M	S	S	-	U
Sodium Hydroxide (10 %)	U	-	M	U	-	-	U	-	M	M	S	S	U	S	U	U	S	S	S	S	S	S	M	S	S	-	U
Barium Salts	M	U	S	-	S	S	S	S	S	S	S	S	S	S	S	M	-	S	S	S	S	S	S	M	S	S	S
Benzene	S	S	U	U	S	U	M	U	S	U	U	S	U	U	U	M	U	M	U	U	U	S	U	U	S	U	S
Benzyl Alcohol	S	-	U	U	-	-	M	M	-	M	-	S	U	U	U	U	U	U	-	M	S	M	-	S	-	S	
Boric Acid	U	S	S	M	S	S	U	S	S	S	S	S	S	S	S	U	S	S	S	S	S	S	S	S	S	S	S
Cesium Acetate	M	-	S	-	S	S	S	-	S	S	S	S	-	S	S	-	-	S	S	S	S	S	S	M	S	S	S
Cesium Bromide	M	S	S	-	S	S	S	-	S	S	S	S	S	S	S	-	-	S	S	S	S	S	S	M	S	S	S
Cesium Chloride	M	S	S	U	S	S	S	-	S	S	S	S	S	S	S	-	-	S	S	S	S	S	S	M	S	S	S
Cesium Formate	M	S	S	-	S	S	S	-	S	S	S	S	S	S	S	-	-	S	S	S	S	S	S	M	S	S	S
Cesium Iodide	M	S	S	-	S	S	S	-	S	S	S	S	S	S	S	-	-	S	S	S	S	S	S	M	S	S	S
Cesium Sulfate	M	S	S	-	S	S	S	-	S	S	S	S	S	S	S	-	-	S	S	S	S	S	S	M	S	S	S
Chloroform	U	U	U	U	S	S	M	U	S	U	U	M	U	M	U	U	U	M	M	U	U	S	U	U	U	M	S

Key

- S Satisfactory
- M Moderate attack, may be satisfactory for use in centrifuge depending on length of exposure, speed involved, etc.; suggest testing under actual conditions of use.
- U Unsatisfactory, not recommended.
- No data available. Because no organized chemical resistance data exists for materials under the stress of centrifugation, when in doubt we recommend pretesting sample lots. suggest testing, using sample to avoid loss of valuable material.

CHEMICAL	MATERIAL	ALUMINUM	ANODIC COATING for ALUMINUM	BUNA N	CELLULOSE ACETATE BUTYRATE	POLYURETHANE ROTOR PAINT	COMPOSITE Carbon Fiber/Epoxy	DELRIN™	ETHYLENE PROPYLENE	GLASS	NEOPRENE	NORYL	NYLON™	PET*, POLYCLEAR™, POLYALLOMER	POLYCARBONATE	POLYESTER, GLASS THERMOSET	POLYTHERMIDE	POLYRTHYLENE	POLYPROPYLENE	POLYSULFONE	POLYVINYL CHLORIDE	RULON A™, TEFLON™	SILICONE RUBBER	STAINLESS STEEL	TITANIUM	TYGON™	VITON™	
Chromic Acid (10 %)	U	-	U	U	S	U	U	-	S	S	S	U	S	S	M	U	M	S	S	U	M	S	M	U	S	S	S	
Chromic Acid (50 %)	U	-	U	U	-	U	U	-	-	-	S	U	U	S	M	U	M	S	S	U	M	S	-	U	M	-	S	
Cresol Mixture	S	S	U	-	-	-	S	-	S	U	U	U	U	U	U	-	-	U	U	-	U	S	S	S	S	U	S	
Cyclohexane	S	S	S	-	S	S	S	U	S	U	S	S	U	U	U	M	S	M	U	M	M	S	U	M	M	U	S	
Deoxycholate	S	S	S	-	S	S	S	-	S	S	S	S	S	S	S	-	-	S	S	S	S	S	S	S	S	S	S	
Distilled Water	S	S	S	S	S	S	S	S	S	S	S	S	S	S	S	S	S	S	S	S	S	S	S	S	S	S	S	
Dextran	M	S	S	S	S	S	S	-	S	S	S	S	S	S	S	S	S	S	S	S	S	S	S	M	S	S	S	
Diethyl Ether	S	S	U	U	S	S	S	U	S	U	U	S	U	U	U	U	U	U	U	U	U	U	S	S	S	S	M	U
Diethyl Ketone	S	-	U	U	-	-	M	-	S	U	-	S	-	M	U	U	U	M	M	-	U	S	-	-	S	U	U	
Diethylpyrocarbonate	S	S	U	-	S	S	S	-	S	S	U	S	U	S	U	-	-	S	S	S	M	S	S	S	S	S	S	
Dimethylsulfoxide	S	S	U	U	S	S	S	-	S	U	S	S	U	S	U	U	-	S	S	U	U	S	S	S	S	U	U	
Dioxane	M	S	U	U	S	S	M	M	S	U	U	S	U	M	U	U	-	M	M	M	U	S	S	S	S	U	U	
Ferric Chloride	U	U	S	-	-	-	M	S	-	M	-	S	-	S	-	-	-	S	S	-	-	-	M	U	S	-	S	
Acetic Acid (Glacial)	S	S	U	U	S	S	U	M	S	U	S	U	U	U	U	U	M	S	U	M	U	S	U	U	S	-	U	
Acetic Acid (5 %)	S	S	M	S	S	S	M	S	S	S	S	S	M	S	S	S	S	S	S	S	M	S	S	M	S	S	M	
Acetic Acid (60 %)	S	S	U	U	S	S	U	-	S	M	S	U	U	M	U	S	M	S	M	S	M	S	M	U	S	M	U	
Ethyl Acetate	M	M	U	U	S	S	M	M	S	S	U	S	U	M	U	U	-	S	S	U	U	S	M	M	S	U	U	
Ethyl Alcohol (50 %)	S	S	S	S	S	S	M	S	S	S	S	S	U	S	U	S	S	S	S	S	S	S	S	M	S	M	U	
Ethyl Alcohol (95 %)	S	S	S	U	S	S	M	S	S	S	S	S	U	S	U	-	S	S	S	M	S	S	S	U	S	M	U	

Key

- S Satisfactory
- M Moderate attack, may be satisfactory for use in centrifuge depending on length of exposure, speed involved, etc.; suggest testing under actual conditions of use.
- U Unsatisfactory, not recommended.
- No data available. Because no organized chemical resistance data exists for materials under the stress of centrifugation, when in doubt we recommend pretesting sample lots. suggest testing, using sample to avoid loss of valuable material.

CHEMICAL	MATERIAL ALUMINUM	ANODIC COATING for ALUMINUM	BUNA N	CELLULOSE ACETATE BUTYRATE	POLYURETHANE ROTOR PAINT	COMPOSITE Carbon Fiber/Epoxy	DELIRIN™	ETHYLENE PROPYLENE	GLASS	NEOPRENE	NORYL	NYLON™	PET*, POLYCLEAR™, POLYALLOMER	POLYCARBONATE	POLYESTER, GLASS THERMOSET	POLYETHERIMIDE	POLYRTHYLENE	POLYPROPYLENE	POLYSULFONE	POLYVINYL CHLORIDE	RULON A™, TEFLON™	SILICONE RUBBER	STAINLESS STEEL	TITANIUM	TYGON™	VITON™	
Ethylene Dichloride	S	-	U	U	-	-	S	M	-	U	U	S	U	U	U	U	U	U	-	U	S	U	-	S	-	S	
Ethylene Glycol	S	S	S	S	S	S	S	S	S	S	S	S	S	-	S	U	S	S	S	S	S	S	S	M	S	M	S
Ethylene Oxide Vapor	S	-	U	-	-	U	-	-	S	U	-	S	-	S	M	-	-	S	S	S	U	S	U	S	S	S	U
Ficoll-Hypaque	M	S	S	-	S	S	S	-	S	S	S	S	-	S	S	-	S	S	S	S	S	S	S	M	S	S	S
Hydrofluoric Acid (10 %)	U	U	U	M	-	-	U	-	-	U	U	S	-	S	M	U	S	S	S	S	M	S	U	U	U	-	-
Hydrofluoric Acid (50 %)	U	U	U	U	-	-	U	-	-	U	U	U	U	S	U	U	U	S	S	M	M	S	U	U	U	-	M
Hydrofluoric Acid (conc.)	U	U	U	U	-	U	U	M	-	U	M	U	U	M	U	U	U	-	S	-	U	S	U	U	U	-	-
Formaldehyde (40 %)	M	M	M	S	S	S	S	M	S	S	S	S	M	S	S	S	U	S	S	M	S	S	S	M	S	M	U
Glutaraldehyde	S	S	S	S	-	-	S	-	S	S	S	S	S	S	S	-	-	S	S	S	-	-	S	S	S	-	-
Glycerol	M	S	S	-	S	S	S	S	S	S	S	S	S	S	S	-	S	S	S	S	S	S	S	S	S	S	S
Guanidine Hydrochloride	U	U	S	-	S	S	S	-	S	S	S	S	S	S	S	-	-	S	S	S	S	S	S	U	S	S	S
Haemo-Sol	S	S	S	-	-	-	S	-	S	S	S	S	S	S	S	-	-	S	S	S	S	S	S	S	S	S	S
Hexane	S	S	S	-	S	S	S	-	S	S	U	S	U	M	U	S	S	U	S	S	M	S	U	S	S	U	S
Isobutyl Alcohol	-	-	M	U	-	-	S	S	-	U	-	S	U	S	S	M	S	S	S	-	S	S	S	-	S	-	S
Isopropyl Alcohol	M	M	M	U	S	S	S	S	S	U	S	S	U	S	U	M	S	S	S	S	S	S	S	M	M	M	S
Iodoacetic Acid	S	S	M	-	S	S	S	-	S	M	S	S	M	S	S	-	M	S	S	S	S	S	M	S	S	M	M

Key

- S Satisfactory
- M Moderate attack, may be satisfactory for use in centrifuge depending on length of exposure, speed involved, etc.; suggest testing under actual conditions of use.
- U Unsatisfactory, not recommended.
- No data available. Because no organized chemical resistance data exists for materials under the stress of centrifugation, when in doubt we recommend pretesting sample lots. suggest testing, using sample to avoid loss of valuable material.

CHEMICAL	MATERIAL ALUMINUM	ANODIC COATING for ALUMINUM	BUNA N	CELLULOSE ACETATE BUTYRATE	POLYURETHANE ROTOR PAINT	COMPOSITE Carbon Fiber/Epoxy	DELRIN™	ETHYLENE PROPYLENE	GLASS	NEOPRENE	NORYL	NYLON™	PET*, POLYCLEAR™, POLYALLOMER	POLYCARBONATE	POLYESTER, GLASS THERMOSET	POLYETHERIMIDE	POLYRTHYLENE	POLYPROPYLENE	POLYSULFONE	POLYVINYL CHLORIDE	RULON A™, TEFLON™	SILICONE RUBBER	STAINLESS STEEL	TITANIUM	TYGON™	VITON™	
Potassium Bromide	U	S	S	-	S	S	S	-	S	S	S	S	S	S	S	S	S	S	S	-	S	S	S	M	S	S	S
Potassium Carbonate	M	U	S	S	S	S	S	-	S	S	S	S	S	S	U	S	S	S	S	S	S	S	S	S	S	S	S
Potassium Chloride	U	S	S	-	S	S	S	S	S	S	S	S	S	S	-	S	S	S	S	S	S	S	S	U	S	S	S
Potassium Hydroxide (5 %)	U	U	S	S	S	S	M	-	S	S	S	S	-	S	U	S	S	S	S	S	S	S	M	U	M	S	U
Potassium Hydroxide (conc.)	U	U	M	U	-	-	M	-	M	S	S	-	U	M	U	U	U	S	M	-	M	U	-	U	U	-	U
Potassium Permanganate	S	S	S	-	S	S	S	-	S	S	S	U	S	S	S	M	-	S	M	S	U	S	S	M	S	U	S
Calcium Chloride	M	U	S	S	S	S	S	S	S	S	S	S	S	S	M	S	-	S	S	S	S	S	S	M	S	S	S
Calcium Hypochlorite	M	-	U	-	S	M	M	S	-	M	-	S	-	S	M	S	-	S	S	S	M	S	M	U	S	-	S
Kerosene	S	S	S	-	S	S	S	U	S	M	U	S	U	M	M	S	-	M	M	M	S	S	U	S	S	U	S
Sodium Chloride (10 %)	S	-	S	S	S	S	S	S	-	-	-	S	S	S	S	S	-	S	S	S	S	-	S	S	M	-	S
Iodoacetic Acid	U	-	S	U	S	S	S	-	-	-	-	S	S	S	S	S	-	S	S	-	S	-	S	S	M	-	S
Carbon Tetrachloride	U	U	M	S	S	U	M	U	S	U	U	S	U	M	U	S	S	M	M	S	M	M	M	M	U	S	S
Aqua Regia	U	-	U	U	-	-	U	-	-	-	-	-	U	U	U	U	U	U	U	-	-	-	-	-	S	-	M
Solution 555 (20 %)	S	S	S	-	-	-	S	-	S	S	S	S	S	S	S	-	-	S	S	S	-	S	S	S	S	S	S
Magnesium Chloride	M	S	S	-	S	S	S	S	S	S	S	S	S	S	S	S	S	S	S	S	S	S	S	M	S	S	S
Mercaptoacetic Acid	U	S	U	-	S	M	S	-	S	M	S	U	U	U	U	-	S	U	U	S	M	S	U	S	S	S	S

Key

- S Satisfactory
- M Moderate attack, may be satisfactory for use in centrifuge depending on length of exposure, speed involved, etc.; suggest testing under actual conditions of use.
- U Unsatisfactory, not recommended.
- No data available. Because no organized chemical resistance data exists for materials under the stress of centrifugation, when in doubt we recommend pretesting sample lots. suggest testing, using sample to avoid loss of valuable material.

CHEMICAL	MATERIAL ALUMINUM	ANODIC COATING for ALUMINUM	BUNA N	CELLULOSE ACETATE BUTYRATE	POLYURETHANE ROTOR PAINT	COMPOSITE Carbon Fiber/Epoxy	DELIRIN™	ETHYLENE PROPYLENE	GLASS	NEOPRENE	NORYL	NYLON™	PET*, POLYCLEAR™, POLYALLOMER	POLYCARBONATE	POLYESTER, GLASS THERMOSET	POLYETHERIMIDE	POLYRTHYLENE	POLYPROPYLENE	POLYSULFONE	POLYVINYL CHLORIDE	RULON A™, TEFLON™	SILICONE RUBBER	STAINLESS STEEL	TITANIUM	TYGON™	VITON™	
Methyl Alcohol	S	S	S	U	S	S	M	S	S	S	S	S	U	S	U	M	S	S	S	S	S	S	M	S	M	U	
Methylene Chloride	U	U	U	U	M	S	S	U	S	U	U	S	U	U	U	U	M	U	U	U	S	S	M	U	S	U	
Methyl Ethyl Ketone	S	S	U	U	S	S	M	S	S	U	U	S	U	S	U	U	S	S	U	U	S	S	S	S	U	U	
Metrizamide	M	S	S	-	S	S	S	-	S	S	S	S	-	S	S	-	-	S	S	S	S	S	M	S	S	S	
Lactic Acid (100 %)	-	-	S	-	-	-	-	-	-	M	S	U	-	S	S	S	M	S	S	-	M	S	M	S	S	-	S
Lactic Acid (20 %)	-	-	S	S	-	-	-	-	-	M	S	M	-	S	S	S	S	S	S	S	M	S	M	S	S	-	S
N-Butyl Alcohol	S	-	S	U	-	-	S	-	-	S	M	-	U	S	M	S	S	S	S	M	M	S	M	-	S	-	S
N-Butyl Phthalate	S	S	U	-	S	S	S	-	S	U	U	S	U	U	U	M	-	U	U	S	U	S	M	M	S	U	S
N, N-Dimethylformamide	S	S	S	U	S	M	S	-	S	S	U	S	U	S	U	U	-	S	S	U	U	S	M	S	S	S	U
Sodium Borate	M	S	S	S	S	S	S	S	S	S	S	U	S	S	S	S	-	S	S	S	S	S	M	S	S	S	
Sodium Bromide	U	S	S	-	S	S	S	-	S	S	S	S	S	S	S	S	-	S	S	S	S	S	M	S	S	S	
Sodium Carbonate (2 %)	M	U	S	S	S	S	S	S	S	S	S	S	S	S	U	S	S	S	S	S	S	S	S	S	S	S	
Sodium Dodecyl Sulfate	S	S	S	-	S	S	S	-	S	S	S	S	S	S	S	-	S	S	S	S	S	S	S	S	S	S	S
Sodium Hypochlorite (5 %)	U	U	M	S	S	M	U	S	S	M	S	S	S	M	S	S	S	M	S	S	S	M	U	S	M	S	
Sodium Iodide	M	S	S	-	S	S	S	-	S	S	S	S	S	S	S	-	-	S	S	S	S	S	M	S	S	S	
Sodium Nitrate	S	S	S	-	S	S	S	S	S	S	S	S	S	S	S	-	S	S	S	S	S	U	S	S	S	S	

Key

- S Satisfactory
- M Moderate attack, may be satisfactory for use in centrifuge depending on length of exposure, speed involved, etc.; suggest testing under actual conditions of use.
- U Unsatisfactory, not recommended.
- No data available. Because no organized chemical resistance data exists for materials under the stress of centrifugation, when in doubt we recommend pretesting sample lots. suggest testing, using sample to avoid loss of valuable material.

CHEMICAL	MATERIAL ALUMINUM	ANODIC COATING for ALUMINUM	BUNA N	CELLULOSE ACETATE BUTYRATE	POLYURETHANE ROTOR PAINT	COMPOSITE Carbon Fiber/Epoxy	DELRIN™	ETHYLENE PROPYLENE	GLASS	NEOPRENE	NORYL	NYLON™	PET*, POLYCLEAR™, POLYALLOMER	POLYCARBONATE	POLYESTER, GLASS THERMOSET	POLYETHERIMIDE	POLYRTHYLENE	POLYPROPYLENE	POLYSULFONE	POLYVINYL CHLORIDE	RULON A™, TEFLON™	SILICONE RUBBER	STAINLESS STEEL	TITANIUM	TYGON™	VITON™		
Sodium Sulfate	U	S	S	-	S	S	S	S	S	S	S	S	S	S	S	S	S	S	S	S	S	S	M	S	S	S		
Sodium Sulfide	S	-	S	S	-	-	-	S	-	-	-	S	S	S	U	U	-	-	S	-	-	-	S	S	M	-	S	
Sodium Sulfite	S	S	S	-	S	S	S	S	M	S	S	S	S	S	M	-	S	S	S	S	S	S	S	S	S	S	S	
Nickel Salts	U	S	S	S	S	S	-	S	S	S	-	-	S	S	S	S	-	S	S	S	S	S	S	M	S	S	S	
Oils (Petroleum)	S	S	S	-	-	-	S	U	S	S	S	S	U	U	M	S	M	U	U	S	S	S	U	S	S	S	S	
Oils (Other)	S	-	S	-	-	-	S	M	S	S	S	S	U	S	S	S	S	U	S	S	S	S	-	S	S	M	S	
Oleic Acid	S	-	U	S	S	S	U	U	S	U	S	S	M	S	S	S	S	S	S	S	S	S	M	U	S	M	M	
Oxalic Acid	U	U	M	S	S	S	U	S	S	S	S	S	U	S	U	S	S	S	S	S	S	S	U	M	S	S		
Perchloric Acid (10 %)	U	-	U	-	S	U	U	-	S	M	M	-	-	M	U	M	S	M	M	-	M	S	U	-	S	-	S	
Perchloric Acid (70 %)	U	U	U	-	-	U	U	-	S	U	M	U	U	M	U	U	U	M	M	U	M	S	U	U	S	U	S	
Phenol (5 %)	U	S	U	-	S	M	M	-	S	U	M	U	U	S	U	M	S	M	S	U	U	S	U	M	M	M	S	
Phenol (50 %)	U	S	U	-	S	U	M	-	S	U	M	U	U	U	U	U	S	U	M	U	U	S	U	U	U	M	S	
Phosphoric Acid (10 %)	U	U	M	S	S	S	U	S	S	S	S	U	-	S	S	S	S	S	S	S	S	S	U	M	U	S	S	
Phosphoric Acid (conc.)	U	U	M	M	-	-	U	S	-	M	S	U	U	M	M	S	S	S	M	S	M	S	U	M	U	-	S	
Physiologic Media (Serum, Urine)	M	S	S	S	-	-	S	-	S	S	S	S	S	S	S	S	S	S	S	S	S	S	S	S	S	S	S	S
Picric Acid	S	S	U	-	S	M	S	S	S	M	S	U	S	S	S	U	S	S	S	S	U	S	U	M	S	M	S	
Pyridine (50 %)	U	S	U	U	S	U	U	-	U	S	S	U	U	M	U	U	-	U	S	M	U	S	S	U	U	U	U	

Key

- S Satisfactory
- M Moderate attack, may be satisfactory for use in centrifuge depending on length of exposure, speed involved, etc.; suggest testing under actual conditions of use.
- U Unsatisfactory, not recommended.
- No data available. Because no organized chemical resistance data exists for materials under the stress of centrifugation, when in doubt we recommend pretesting sample lots. suggest testing, using sample to avoid loss of valuable material.

CHEMICAL	MATERIAL ALUMINUM	ANODIC COATING for ALUMINUM	BUNA N	CELLULOSE ACETATE BUTYRATE	POLYURETHANE ROTOR PAINT	COMPOSITE Carbon Fiber/Epoxy	DELRIN™	ETHYLENE PROPYLENE	GLASS	NEOPRENE	NORYL	NYLON™	PET*, POLYCLEAR™, POLYALLOMER	POLYCARBONATE	POLYESTER, GLASS THERMOSET	POLYETHERIMIDE	POLYRTHYLENE	POLYPROPYLENE	POLYSULFONE	POLYVINYL CHLORIDE	RULON A™, TEFLON™	SILICONE RUBBER	STAINLESS STEEL	TITANIUM	TYGON™	VITON™	
Rubidium Bromide	M	S	S	-	S	S	S	-	S	S	S	S	S	S	-	-	S	S	S	S	S	S	M	S	S	S	
Rubidium Chloride	M	S	S	-	S	S	S	-	S	S	S	S	S	S	-	-	S	S	S	S	S	S	M	S	S	S	
Sucrose	M	S	S	-	S	S	S	S	S	S	S	S	S	S	S	S	S	S	S	S	S	S	S	S	S	S	
Sucrose, Alkaline	M	S	S	-	S	S	S	-	S	S	S	S	S	U	S	S	S	S	S	S	S	S	M	S	S	S	
Sulfosalicylic Acid	U	U	S	S	S	S	S	-	S	S	S	U	S	S	-	S	S	S	-	S	S	S	U	S	S	S	
Nitric Acid (10 %)	U	S	U	S	S	U	U	-	S	U	S	U	-	S	S	S	S	S	S	S	S	M	S	S	S	S	
Nitric Acid (50 %)	U	S	U	M	S	U	U	-	S	U	S	U	U	M	M	U	M	M	M	S	S	S	U	S	S	M	S
Nitric Acid (95 %)	U	-	U	U	-	U	U	-	-	U	U	U	U	M	U	U	U	U	M	U	U	S	U	S	S	-	S
Hydrochloric Acid (10 %)	U	U	M	S	S	S	U	-	S	S	S	U	U	S	U	S	S	S	S	S	S	S	U	M	S	S	
Hydrochloric Acid (50 %)	U	U	U	U	S	U	U	-	S	M	S	U	U	M	U	U	S	S	S	S	M	S	M	U	U	M	M
Sulfuric Acid (10 %)	M	U	U	S	S	U	U	-	S	S	M	U	S	S	S	S	S	S	S	S	S	U	U	U	S	S	
Sulfuric Acid (50 %)	M	U	U	U	S	U	U	-	S	S	M	U	U	S	U	U	M	S	S	S	S	U	U	U	M	S	
Schwefelsäure (konz.)	M	U	U	U	-	U	U	M	-	-	M	U	U	S	U	U	U	M	S	U	M	S	U	U	U	-	S
Stearic Acid	S	-	S	-	-	-	S	M	S	S	S	S	-	S	S	S	S	S	S	S	S	M	M	S	S	S	
Tetrahydrofuran	S	S	U	U	S	U	U	M	S	U	U	S	U	U	U	-	M	U	U	U	U	S	U	S	S	U	U
Toluene	S	S	U	U	S	S	M	U	S	U	U	S	U	U	U	S	U	M	U	U	U	S	U	S	U	U	M
Trichloroacetic Acid	U	U	U	-	S	S	U	M	S	U	S	U	U	S	M	-	M	S	S	U	U	S	U	U	U	M	U

Key

- S Satisfactory
- M Moderate attack, may be satisfactory for use in centrifuge depending on length of exposure, speed involved, etc.; suggest testing under actual conditions of use.
- U Unsatisfactory, not recommended.
- No data available. Because no organized chemical resistance data exists for materials under the stress of centrifugation, when in doubt we recommend pretesting sample lots. suggest testing, using sample to avoid loss of valuable material.

CHEMICAL	MATERIAL ALUMINUM	ANODIC COATING for ALUMINUM	BUNA N	CELLULOSE ACETATE BUTYRATE	POLYURETHANE ROTOR PAINT	COMPOSITE Carbon Fiber/Epoxy	DELIRIN™	ETHYLENE PROPYLENE	GLASS	NEOPRENE	NORYL	NYLON™	PET*, POLYCLEAR™, POLYALLOMER	POLYCARBONATE	POLYESTER, GLASS THERMOSET	POLYETHERIMIDE	POLYRTHYLENE	POLYPROPYLENE	POLYSULFONE	POLYVINYL CHLORIDE	RULON A™, TEFLON™	SILICONE RUBBER	STAINLESS STEEL	TITANIUM	TYGON™	VITON™	
Trichloroethane	S	-	U	-	-	-	M	U	-	U	-	S	U	U	U	U	U	U	U	U	S	U	-	S	-	S	
Trichloroethylene	-	-	U	U	-	-	-	U	-	U	-	S	U	U	U	U	U	U	U	U	S	U	-	U	-	S	
Trisodium Phosphate	-	-	-	S	-	-	M	-	-	-	-	-	-	S	-	-	S	S	S	-	-	S	-	-	S	-	S
Tris Buffer (neutral pH)	U	S	S	S	S	S	S	-	S	S	S	S	S	S	S	S	S	S	S	S	S	S	S	S	S	S	
Triton X-100	S	S	S	-	S	S	S	-	S	S	S	S	S	S	S	S	S	S	S	S	S	S	S	S	S	S	
Urea	S	-	U	S	S	S	S	-	-	-	-	S	S	S	M	S	S	S	S	-	S	S	S	M	S	-	S
Hydrogen Peroxide (10 %)	U	U	M	S	S	U	U	-	S	S	S	U	S	S	S	M	U	S	S	S	S	S	S	M	S	U	S
Hydrogen Peroxide (3 %)	S	M	S	S	S	-	S	-	S	S	S	S	S	S	S	M	S	S	S	S	S	S	S	S	S	S	
Xylene	S	S	U	S	S	S	M	U	S	U	U	U	U	U	M	U	M	U	U	U	S	U	M	S	U	S	
Zinc Chloride	U	U	S	S	S	S	U	S	S	S	S	S	S	S	S	S	S	S	S	S	S	S	S	U	S	S	
Zinc Sulfate	U	S	S	-	S	S	S	S	S	S	S	S	S	S	S	S	S	S	S	S	S	S	S	S	S	S	
Citric Acid (10 %)	M	S	S	M	S	S	M	S	S	S	S	S	S	S	S	M	S	S	S	S	S	S	S	S	S	S	

*Polyethyleneterephthalate

Key

- S Satisfactory
- M Moderate attack, may be satisfactory for use in centrifuge depending on length of exposure, speed involved, etc. Suggest testing under actual conditions of use.
- U Unsatisfactory, not recommended.
- No data available. Because no organized chemical resistance data exists for materials under the stress of centrifugation, when in doubt we recommend pretesting sample lots. suggest testing, using sample to avoid loss of valuable material.

Note: Chemical resistance data is included only as a guide to product use. Because no organized chemical compatibility data exists for materials under the stress of centrifugation, when in doubt we recommend pretesting sample lots.

Trademarks and Owners

DELRIN, CLEARCRIMP: E. I. du Pont de Nemours and Company

NORYL: AABIC Innovative Plastics IP B.V.

POLYCLEAR: ICL SPECIALTY PRODUCTS, INC.

RULON A, TYGON: Saint-Gobain Performance Plastics

TEFLON: The Chemours Company FC

VITON: FKM

WEEE Compliance

WEEE Compliance. This product is required to comply with the European Union's Waste Electrical & Electronic Equipment (WEEE) Directive 2012/19/EU. It is marked with the following symbol. Fisher Scientific has contracted with one or more recycling/disposal companies in each EU Member State, and this product should be disposed of or recycled through them. Further information on our compliance with these Directives, the recyclers in your country, and information on Scientific products which may assist the detection of substances subject to the RoHS Directive are available at www.thermofisher.com/WEEERoHS under Services & Support.

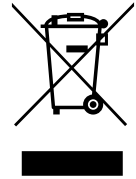

WEEE Konformität. Dieses Produkt muss die EU Waste Electrical & Electronic Equipment (WEEE) Richtlinie 2012/19/EU erfüllen. Das Produkt ist durch folgendes Symbol gekennzeichnet. Fisher Scientific hat Vereinbarungen getroffen mit Verwertungs-/Entsorgungsanlagen in allen EU-Mitgliedstaaten und dieses Produkt muss durch diese Firmen wiederverwertet oder entsorgt werden. Mehr Informationen über die Einhaltung dieser Anweisungen durch Scientific, die Verwerter und Hinweise die Ihnen nützlich sein können, die Fisher Scientific Produkte zu identifizieren, die unter diese RoHS. Anweisung fallen, finden Sie unter www.thermofisher.com/WEEERoHS unter Services & Support.

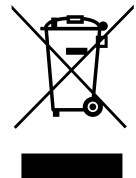

Conformità WEEE. Questo prodotto deve rispondere alla direttiva dell'Unione Europea 2012/19/EU in merito ai Rifiuti degli Apparecchi Elettrici ed Elettronici (WEEE). È marcato col seguente simbolo. Fisher Scientific ha stipulato contratti con una o diverse società di riciclaggio/smaltimento in ognuno degli Stati Membri Europei. Questo prodotto verrà smaltito o riciclato tramite queste medesime. Ulteriori informazioni sulla conformità di Fisher Scientific con queste Direttive, l'elenco delle ditte di riciclaggio nel Vostro paese e informazioni sui prodotti Scientific che possono essere utili alla rilevazione di sostanze soggette alla Direttiva RoHS sono disponibili sul sito www.thermofisher.com/WEEERoHS in Servizi e Supporto.

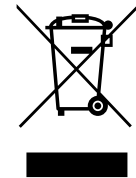

Conformité WEEE. Ce produit doit être conforme à la directive euro-péenne (2012/19/EU) des Déchets d'Equipements Electriques et Electroniques (DEEE). Il est marqué par le symbole suivant. Fisher Scientific s'est associé avec une ou plusieurs compagnies de recyclage dans chaque état membre de l'union européenne et ce produit devrait être collecté ou recyclé par celles-ci. Davantage d'informations sur la conformité de Fisher Scientific à ces directives, les recycleurs dans votre pays et les informations sur les produits Fisher Scientific qui peuvent aider la détection des substances sujettes à la directive RoHS sont disponibles sur www.thermofisher.com/WEEERoHS sous Services et Assistance.



Cumplimiento de la directiva RAEE. Este producto está obligado a cumplir con la Directiva de la Unión Europea sobre residuos de aparatos eléctricos y electrónicos (RAEE) 2012/19/EU. Está marcado con el siguiente símbolo. Fisher Scientific ha contratado a una o varias empresas de reciclado/disposición de residuos en cada estado miembro de la UE, y este producto debe reciclarse o desecharse a través de dichas empresas. Para obtener más información sobre nuestro cumplimiento con estas directivas, las empresas de reciclaje de su país, así como información sobre los productos Scientific que pueden ayudarle a detectar sustancias sujetas a la directiva RoHS, visite www.thermofisher.com/WEEERoHS en la sección Servicios y Asistencia.



IF YOU NEED ASSISTANCE:

Fisher Scientific products are backed by a global technical support team ready to support your applications. We offer cold storage accessories, including remote alarms, temperature recorders, and validation services. Visit eu.fishersci.com or call:

Countries	Sales	Services
Austria	+43 (0)800 20 88 40 at.fishersci.com	+43 1 333 50340 unity.at@thermofisher.com
Belgium	+32 (0)56 260 260 be.fishersci.com	+32 (0) 9 272 54 80 unity.bnl@thermofisher.com
Denmark	+45 70 27 99 20 fishersci.dk	+45 70 23 62 67 unity.dk@thermofisher.com
Germany	+49 (0)2304 9325 de.fishersci.com	+49 6103 408 1050 unity.de@thermofisher.com
Ireland	+353 (0)1 885 5854 ie.fishersci.com	+44 870 241 1034 unity.ie@thermofisher.com
Italy	+39 02 950 59 478 it.fishersci.com	+39 800 823 162 unity.it@thermofisher.com
Finland	+358 (0)9 8027 6280 fishersci.fi	+46 8 556 468 20 unity.fi@thermofisher.com
France	+33 (0)3 88 67 14 14 fr.fishersci.com	+33 1 60 92 49 50 unity.fr@thermofisher.com
Netherlands	+31 (0)20 487 70 00 nl.fishersci.com	+31 (0) 76 579 55 55 unity.bnl@thermofisher.com
Norway	+47 22 95 59 59 fishersci.no	+46 8 556 468 20 unity.no@thermofisher.com
Portugal	+351 21 425 33 50 pt.fishersci.com	+34 913 806 733 unity.pt@thermofisher.com
Spain	+34 902 239 303 es.fishersci.com	+34 913 806 733 unity.es@thermofisher.com
Sweden	+46 31 352 32 00 fishersci.se	+ 46 8 556 468 20 unity.se@thermofisher.com
Switzerland	+41 (0)56 618 41 11 ch.fishersci.com	+ 41(0)61 716 77 40 unity.ch@thermofisher.com
UK	+44 (0)1509 555 500 fishersci.co.uk	+44 870 241 1034 unity.uk@thermofisher.com

fisherbrand

Thermo Fisher Scientific
Zweigniederlassung Osterode
Am Kalkberg, 37520 Osterode am Harz
Germany

50156459 is the original instruction manual.

Find out more at eu.fishersci.com

50156459-b
15808722, 15818722

 **fisher** scientific
part of **Thermo Fisher Scientific**